



SQC310 Series

Thin Film Deposition Controllers

HIGHLY ACCURATE
SEQUENTIAL OR CO-DEPOSITION CONTROL

THE MOST AFFORDABLE, ADVANCED MULTI-LAYER CONTROLLER—FROM THE TECHNOLOGY LEADER

With advanced electronics, an improved display, and a very affordable price, the INFICON SQC310 Series gives you features not found on competitors' thin film controllers. And you can choose the ideal model for your application: sequential deposition (SQC310) or co-deposition (SQC310C).

For sequential deposition, the SQC310 features 2 sensor inputs, 2 source outputs, and 8 digital inputs/outputs, with an optional expansion card that doubles these numbers. For co-deposition, the SQC310C controller monitors up to 4 quartz crystal sensors, with 4 PID control outputs, 16 digital inputs, and 16 relay outputs to the same specs as the SQC310.

WORLDWIDE SUPPORT: OUR EXPERTISE IS YOUR COMPETITIVE ADVANTAGE

INFICON is the only manufacturer of thin film deposition controllers with local service and technical support around the world—including a broad selection of sensors, feedthroughs, and accessories to complement the SQC310 Series controllers. When you purchase your SQC310 series instrument—or any other INFICON product—you can be assured of fast answers, attentive service, and maximum uptime.

FEATURES AT A GLANCE

- Bright, ¼ VGA active matrix color LCD display – available in English or Chinese.
- Standard RS-232 and USB (with Ethernet option).
- Easy setup and operation with a “Quick Setup” Menu, 6 context-sensitive push buttons, and convenient parameter setting knob.
- Windows® program for developing, testing, and downloading processes, and for logging instrument data to your PC for process analysis and quality control.
- Accurate process control, especially for low deposition rates, with ± 0.03 Hz resolution at 10 readings/second, and with ± 2 ppm frequency stability over 0 to 50C.
- Storage capacity for up to 100 processes, 1,000 layers, 50 films.
- Monitoring of source material with a single sensor or with multiple sensors to provide accurate source distribution monitoring.

SPECIFICATIONS

	SQC310	SQC310C
Measurement		
QCM Inputs	2 (4 optional)	4
Frequency Range	4 to 6 MHz	
Frequency Resolution	± 0.03 Hz at 0.10 sec measurement period	
Frequency Stability	± 2 ppm total, 0 to 50C	
Measurement Rate	1 to 10 Hz	
Rate Display	0.01 Å/sec	
Control		
Storage	100 processes, 1000 layers, 50 films	
Control Outputs	2 (4 optional)	4
Output Signal	± 0 to 10 VDC, 15 bits	
Digital Inputs/Relays	8 (16 optional)	16
Digital Inputs	5 VDC non-isolated	
Relays	SPST Form 1A, 30V, 2A max	
Interface(s)	RS-232 and USB (Ethernet optional)	
Remote Power Control	Optional	
Display		
Type	1/4 VGA 320 x 240 active matrix color LCD	
Graphs	Rate, deviation, power or full screen numeric	
General		
Power	100-240 VAC, 50/60 Hz, 25 W	
Compliance	CE	
Windows® Software	Included	
Housing / Mounting	5 1/4" half-rack	

ORDERING INFORMATION

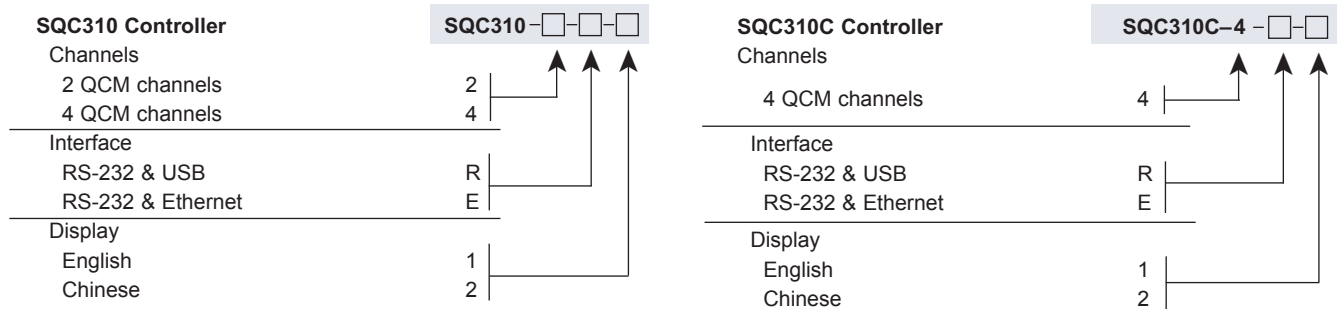

Example of a complete system:

- | | |
|--|---|
| <p>SQC310-2-R-1</p>

<p>782-934-003-10</p> | <p>SQC310 sequential controller with 2 channels, RS232 and USB interface, and English display</p>

<p>Oscillator kit- includes 782-900-010 Oscillator, 782-902-011 6" (150mm) BNC cable, male/female, and 782-902-012-10 10' (3m) BNC cable, male/male.</p> |
|--|---|

